

SPONSORS PATROCINADORES



Friends of the
Cornelius
Public Library



Also Sponsored by:
Human Bean, McMenamins, Wilco



READING LOG REGISTRO DE LECTURA



RATHER DO IT ONLINE
THROUGH BEANSTACK?

¿PREFIERES PARTICIPAR EN
LÍNEA EN BEANSTACK?



**NEED HELP
LOGGING IN?
¿NECESITAS
AYUDA PARA
INICIAR
SESIÓN?**

Name
Nombre

E-mail

Phone #
de Teléfono

1. Track your reading progress: Color in a book in this log for every 30 minutes read

Registra el progreso de tu lectura: Colorea un libro en este registro por cada 30 minutos leídos

2. Submit the completed log between **July 17-August 31** to participate in the **Final Prize Drawing** on **September 6**

Regresa este registro completo entre el **17 de Julio** y el **31 de Agosto** para que participes en el **Sorteo Final** el **6 de Septiembre**

1370 N Adair St. Cornelius, OR 97113
503.357.4093 | www.corneliusor.gov/library
Sat-Tues: 10am-6pm | Wed-Fri: 10am-8pm

  @CorneliusLibrary

 Cornelius
Public Library

2023

START
INICIO

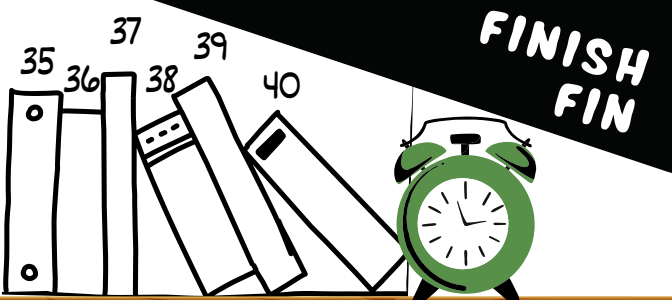
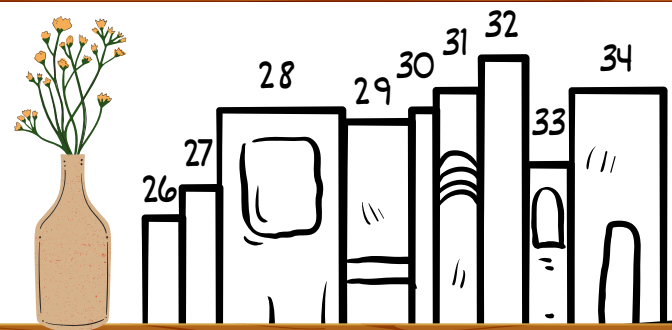
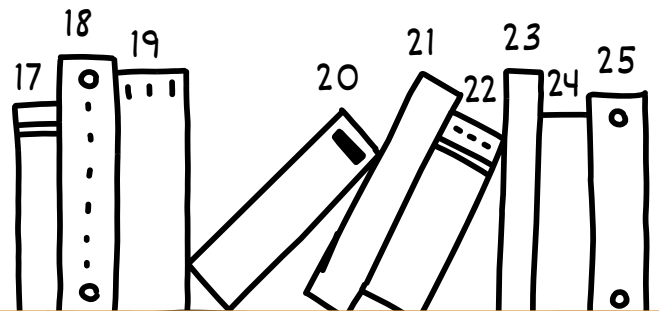
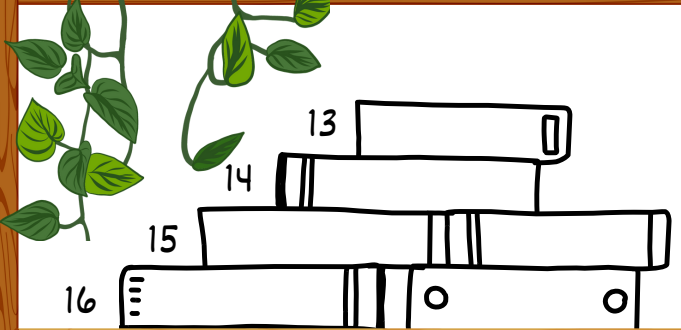
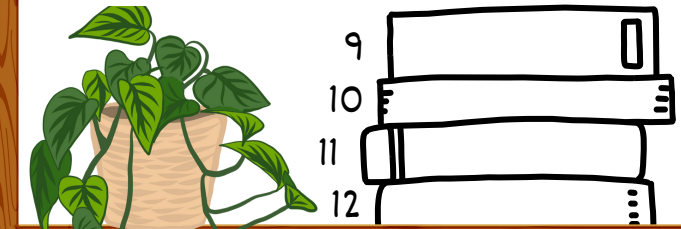

SUMMER READING EVENTS GUÍA DE EVENTOS DE LECTURA DE VERANO

JUNE
JUNIO
01

Summer Reading Kick Off
Inicio del Reto de Lectura de Verano
Family Friendly | Para Toda La Familia
5:30pm-7:30pm

JUNE
JUNIO
08

Decoupage Coasters
Posavasos
Adults | Para Adultos
6:30pm-7:30pm

JUNE
JUNIO
22

How Latinx Youth Made History in Washington County
Cómo la juventud latina hizo historia en el condado de Washington
Adults | Para Adultos
6:30pm-7:30pm

JULY
JULIO
13

Moss Art
Arte con Musgo
Adults | Para Adultos
6:30pm-7:30pm

JULY
JULIO
27

Plates & Pens
Platos y Plumas
Adults | Para Adultos
6:30pm-7:30pm

AUGUST
AGOSTO
10

Paint Pouring
Vertido de Pintura
Adults | Para Adultos
6:30pm-7:30pm

AUGUST
AGOSTO
24

Citizen Activism 101: Making Change Happen
Adults | Para Adultos
6:30pm-7:30pm

To learn more about our other events visit wccl.org and click "events"

Para obtener más información sobre nuestros otros eventos, visita wccl.org y haz clic en "events"